

Blenheim Recliner

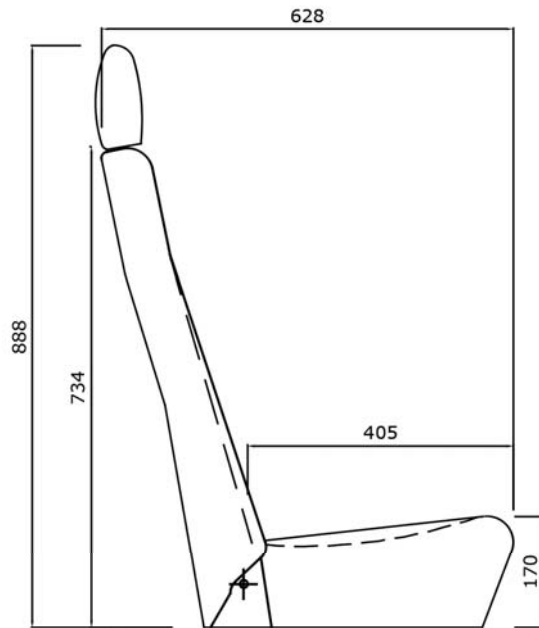

M2/M3 Category Vehicles



i Standard seat weight measures the seat, seat belt and stalk only

Testing Criteria

Tested to the latest versions of the applicable ECE Regulations

- ECE R.14 for seatbelt anchorages.
- ECE R.16 for safety belts.
- ECE R.118 concerning burning behaviour and/or capability to repel fuel or lubricant of materials - *M3 category vehicles only*

Attachment Fittings

- Standard fit pedestals
- Unwin standard lockables
- Unwin HALS
- Kollar standard lockables
- NMI Millenium fitting
- Various T bolts

Tested on a wide range of leg heights and centres.

i For full range of leg testing specifications, please enquire through our sales team

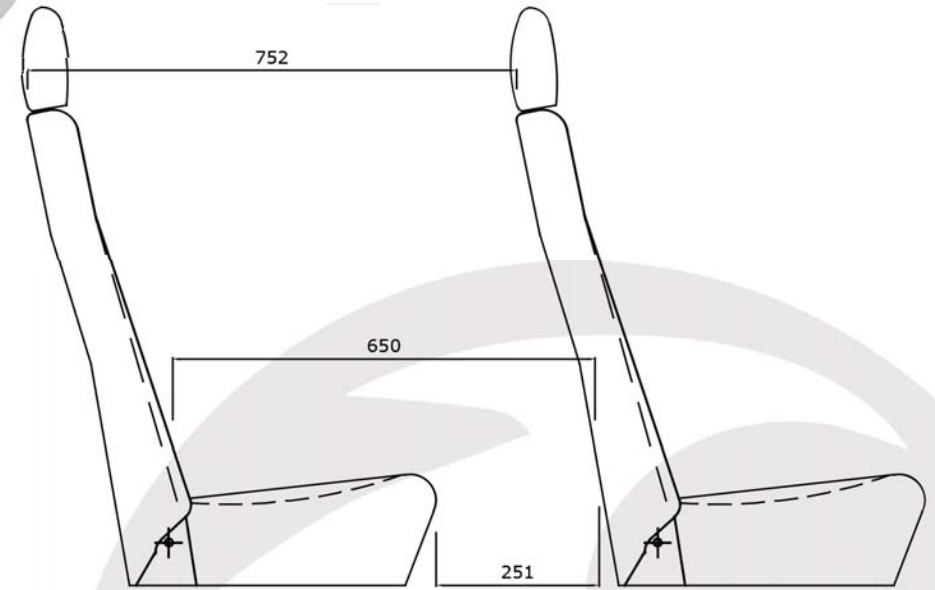

Weight - 15.4kgs

Flooring Systems

- Standard fit pedestals
- Unwin standard lockables

i Cushion widths available:
400mm, 425mm & 450mm on single units



All rights reserved. This document, its content and drawings are property of Phoenix Seating Limited. It is for general information only and must not be copied, replicated or used elsewhere without consent from Phoenix Seating Limited.