

Blenheim Recliner

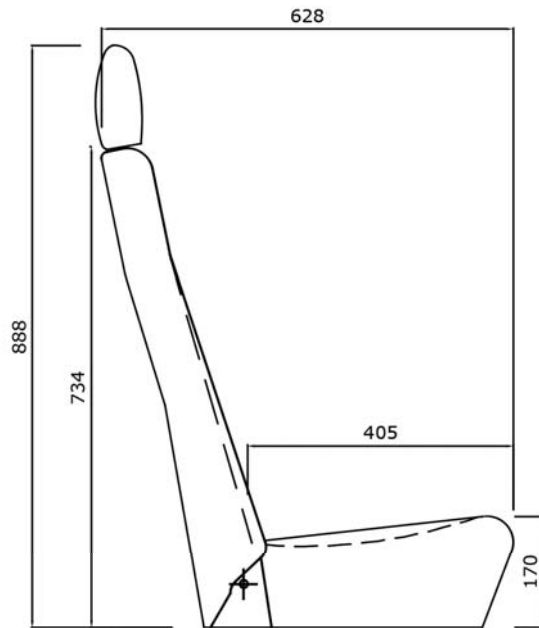

M1 Category Vehicles



Weight - 18.1kgs

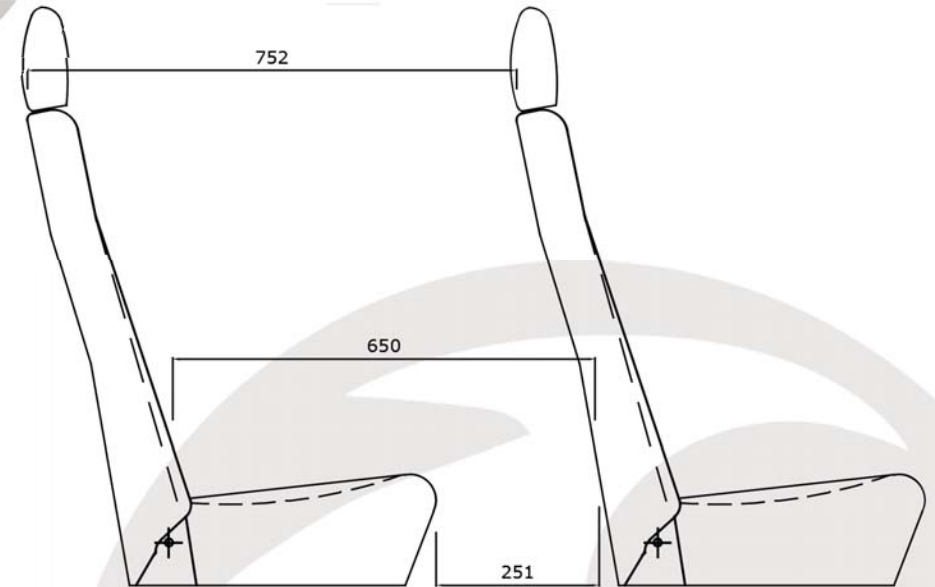

i Standard seat weight measures the seat, seat belt and stalk only

Testing Criteria

Attachment Fittings

Flooring Systems

Tested to the latest versions of the applicable ECE Regulations

- ECE R.14 for seatbelt anchorages.
- ECE R.16 for safety belts.

- Standard fit pedestals
- Unwin standard lockables
- Unwin HALS
- Kollar standard lockables
- NMI Millenium fitting
- Various T bolts

- Standard fit pedestals
- Unwin standard lockables

i Cushion widths available:
400mm, 425mm & 450mm on single units

Tested on a wide range of leg heights and centres.

i For full range of leg testing specifications, please enquire through our sales team



All rights reserved. This document, its content and drawings are property of Phoenix Seating Limited. It is for general information only and must not be copied, replicated or used elsewhere without consent from Phoenix Seating Limited.