

Blenheim Draco

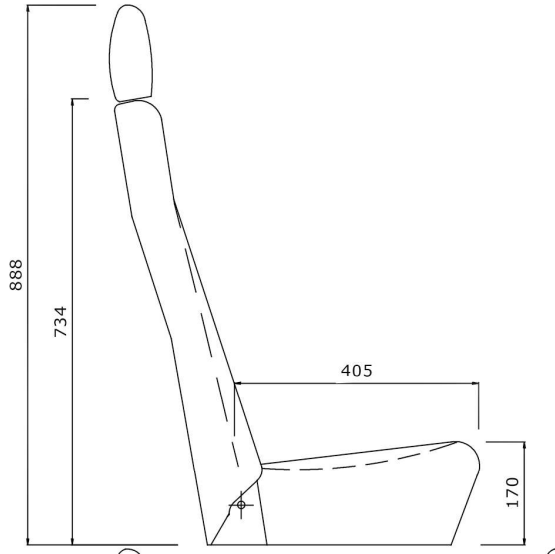

M1 Category Vehicles



Approx. Weight - 15.2kgs

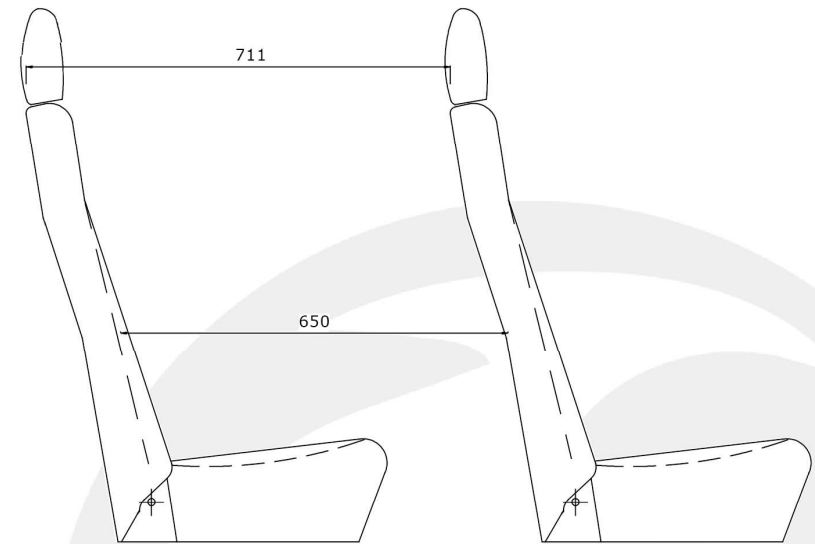

Testing

Tested to the latest versions of the applicable ECE Regulations

- ECE R.17 for seats & their anchorages, performance of head restraints for M1 category vehicles.
- ECE R.14 for seatbelt anchorages.
- ECE R.16 for safety belts and ISOFIX child restraint systems.
- Regulation 44.04 for ISOFIX anchorage systems

Availability

- Single units available in two cushion widths: 425mm & 450mm

Fittings

- Standard fit pedestals
- Unwin standard lockables & HAL
- Koller standard lockables
- NMI Millenium fitting
- Various T bolts

Tested on a wide range of leg heights and centres.



All rights reserved. This document, its content and drawings are property of Phoenix Seating Limited. It is for general information only and must not be copied, replicated or used elsewhere without consent from Phoenix Seating Limited.

sales@phoenixseating.com | 01384 296622 | www.phoenixseating.com