

BLLENHEIM

FEATURES

- Manufactured for all vehicle markets, the Blenheim seating range was designed for maximum comfort and functionality.
- Tested to M1, M2 and M3 Standard EEC directive 76/115 (as amended) using an accredited test centre in the U.K.
- Tested on Koller Quick Release Mechanisms
- Seat belt mechanism is fully encapsulated within the seat structure.
- Fully removable seat back covers.
- Internal seat belt.

SPECIFICATION

- Available in five finished seat widths: 400mm, 425mm 450mm, 475mm & 500mm
- Single, double and treble units available.
- Leg heights from 200mm to 330mm (Tested max.)
- Adjustable leg centres.
- Tested with NMI Millennium System.
- Tested with Unwin Anti-rattle quick release mechanisms.
- Retrofit mountings for approved armrests.
- Retrofit mountings for approved headrests.
- ABS back.
- 15kg

ACCESSORIES

- Open P.U. headrest in various colours.
- Dual Colour Metro Grab handle
- Moulded folding armrest.
- Corner and rear grabhandle in varying specifications.
- All ages seat belt.
- Trimmed headrest.
- ABS back.
- Coach rear grab.
- Moulded fixed ring armrest.
- Ashtray.





BLENHEIM

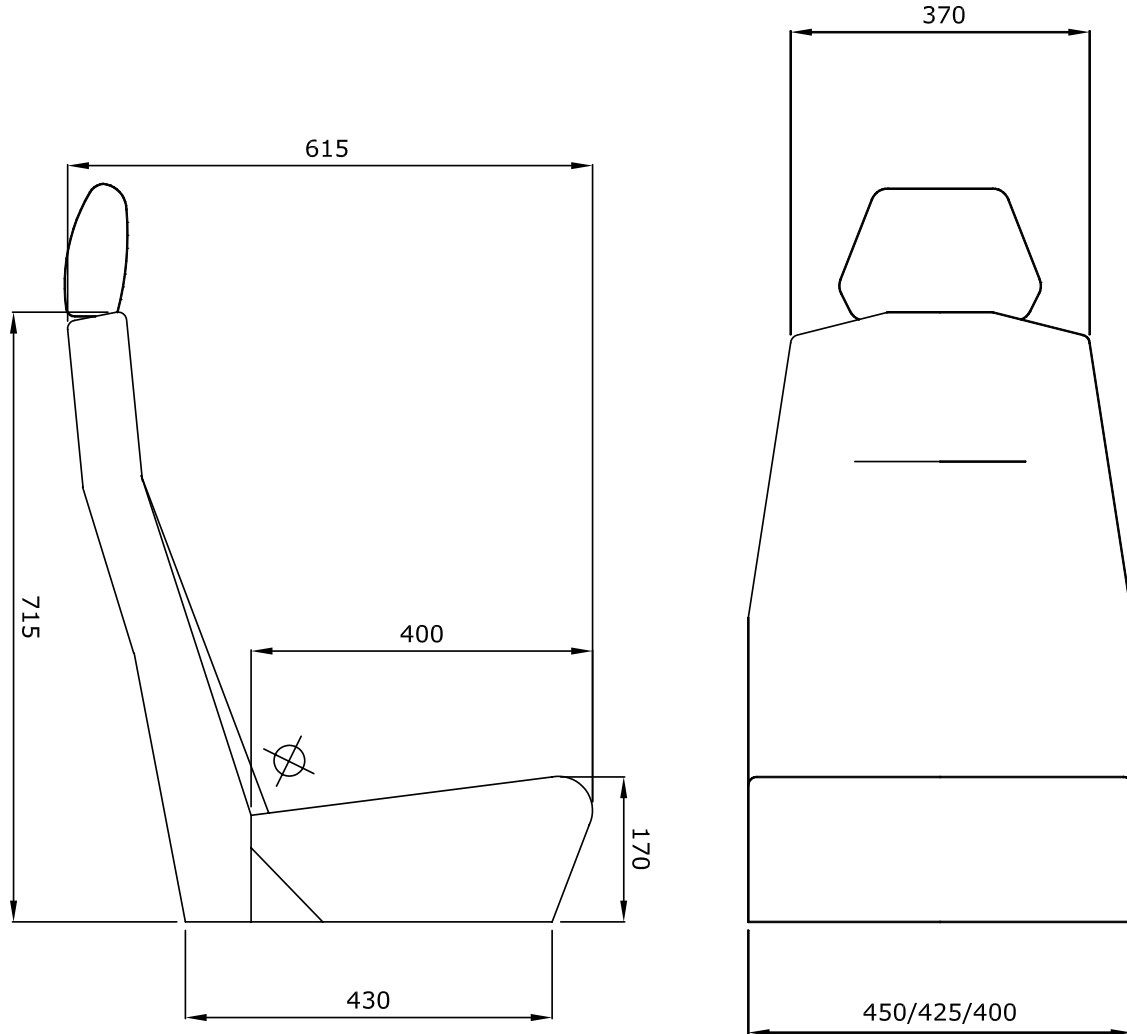

WEIGHT

SEAT WITH BELT - 15a KGS (Legs & Quick Removal Not Included)

DIMENSIONS

Add 150mm to the overall height of the seat by adding either a trimmed or PU Headrest.

TEST PASSED

96/36 Seat Belt Anchorage, 96/37 Dynamic Seat Strength & Rear Impact, 96/38 Seat Belt, EEC Directive 76/115 (As Amended). This seat meets all test load and dimensional criteria for R14. ISOFIX seat tested to R14 & R44.