

BALMORAL

FEATURES

- Manufactured for the coach market, the Balmoral seat is designed to maximise the gangway width without compromising passenger comfort.
- Tested to M2 and M3 Standard EEC directive 76/115 (as amended) using an accredited test centre in the U.K.
- Seat belt reel mechanism is beneath the seat structure.
- Fully removable seat back covers.

SPECIFICATION

- Available in three seat widths: 400, 425, 450mm.
- Single, double and treble units available.
- Leg heights from 200mm to 330mm (tested max.)
- Adjustable leg centres.
- Tested with Unwin Anti-rattle quick release mechanisms.
- Retrofit mountings for approved armrests.

ACCESSORIES

- Moulded folding armrest
- Corner & rear grabhandle in varying specifications.
- Coach rear grab.
- Moulded fixed ring armrest.
- Ashtray.





BALMORAL

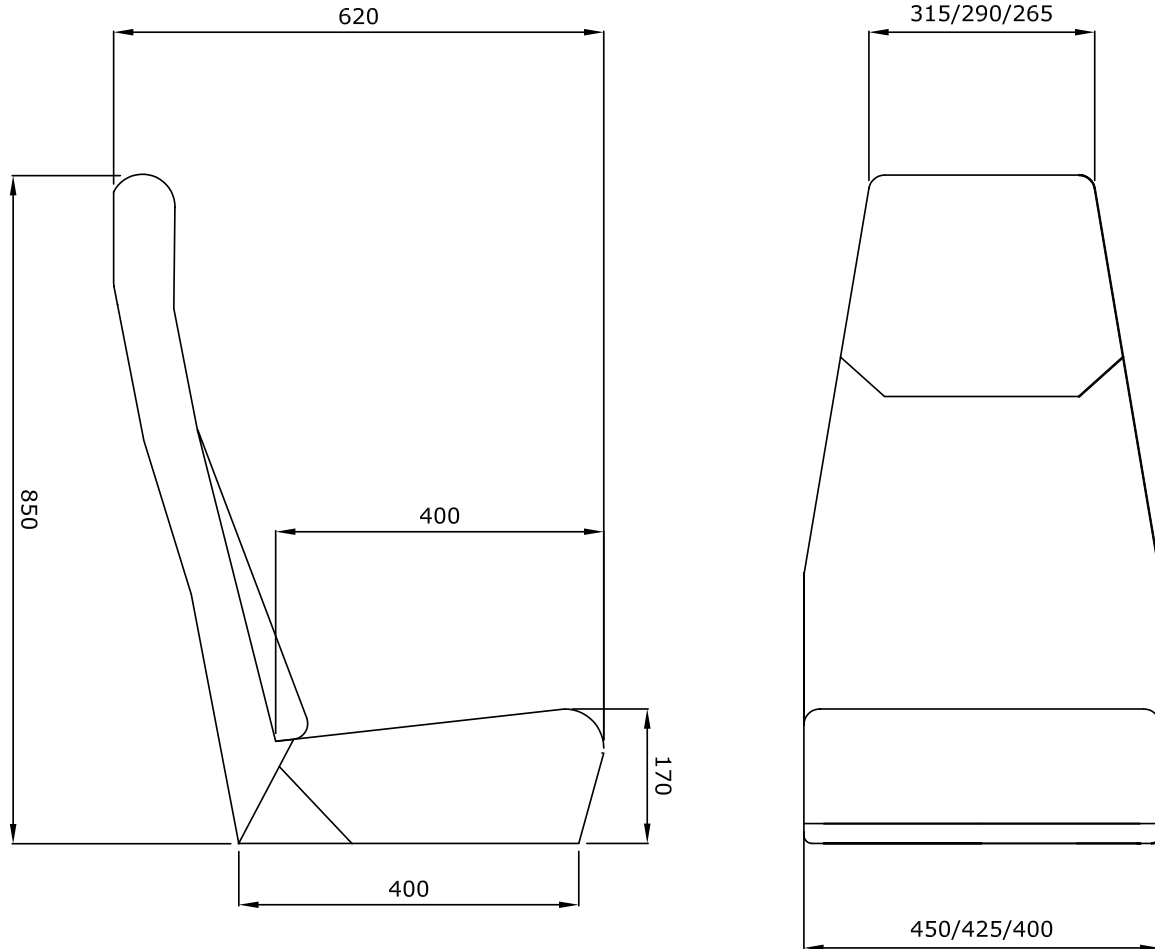

WEIGHT

SEAT WITH BELT - 12 KGS (Legs & Quick Removal Not Included)

TEST PASSED

96/36 Seat Belt Anchorage, 96/37 Dynamic Seat Strength & Rear Impact, 96/38 Seat Belt, EEC Directive 76/115 (As Amended). This seat meets all test load and dimensional criteria for R14. ISOFIX seat tested to R14 & R44. M2 & M3.